

**CADWELD®**

**Installers and  
Inspectors  
Guide for  
CADWELD®  
Electrical  
Connections**

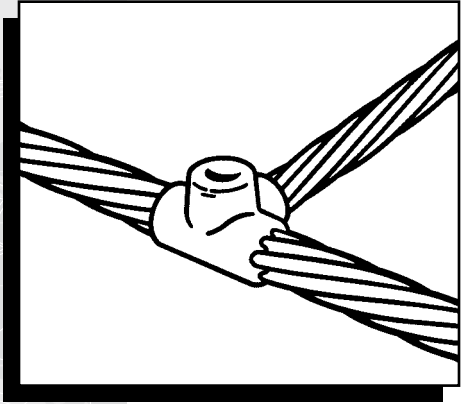

**ERICO®**

This handbook is designed to guide the person in the field with the installation and inspection of CADWELD® exothermic welds, including CADWELD® EXOLON and CADWELD® ONE SHOT styles.

The parameters and criteria outlined in this manual are based on tests performed by ERICO, and on our years of experience using CADWELD materials in the field to develop exothermic technology.

If you have any questions about the materials and methods used in the CADWELD process, contact your local CADWELD representative or ERICO at [www.erico.com](http://www.erico.com)



# Contents

The CADWELD® Process .....	4
The CADWELD Connection .....	5
It's Easy to Make CADWELD Connections .....	6
CADWELD Quality Standards .....	8
Specifications for CADWELD Connections .....	8
CADWELD Mold Inspection .....	9
Inspection of CADWELD Connections	
General Indicators .....	10
Size .....	10
Color .....	12
Surface Finish .....	12
Porosity .....	12
Visual Inspection .....	13
Photographic Guides .....	14
Field Situation Guide .....	18
CADWELD® ONE SHOT Connections	
General Indicators .....	22
Field Situation Guide for CADWELD ONE SHOT Applications .....	23

# The CADWELD® Process

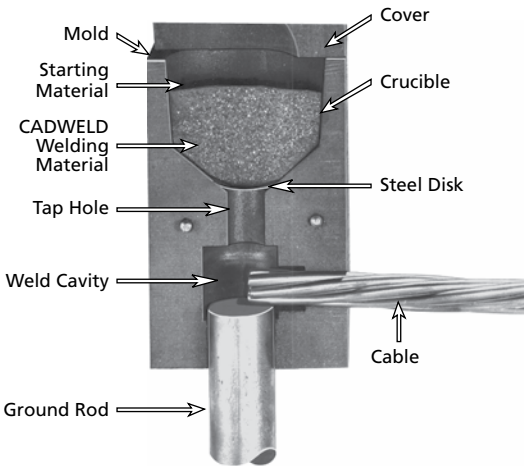

The CADWELD® process is a method of making electrical connections of copper to copper or copper to steel in which no outside source of heat or power is required.

In this process, granular metals (granular copper oxide and aluminum) are dumped from a container into a graphite crucible and ignited.

The reduction of the copper oxide by the aluminum (exothermic reaction) produces molten copper and aluminum oxide slag. The slag floats to the surface and the disk melts, allowing molten copper to flow into the weld cavity and complete the weld. The weld is allowed to solidify. The mold is removed and made ready for the next weld. The process takes seconds to complete.

**BEFORE WELDING: READ, UNDERSTAND  
AND FOLLOW ALL SAFETY INSTRUCTIONS  
PACKAGED WITH YOUR MOLD!**



The CADWELD® process is applicable to materials other than copper. Some of these materials are:

Common steel	Brass	Galvanized and bethanized steel
Chromax*	Wrought iron	Bronze
Everdur®	Stainless steel	Commercially pure iron
Steel rail	Cor-Ten®	Silicon bronze
Copper-clad steel	Monel	Nichrome*
Columbium	Cast iron	Nichrome V*
Niobium	Kama*	

\*Resistance Heater Materials

## The CADWELD® Connection

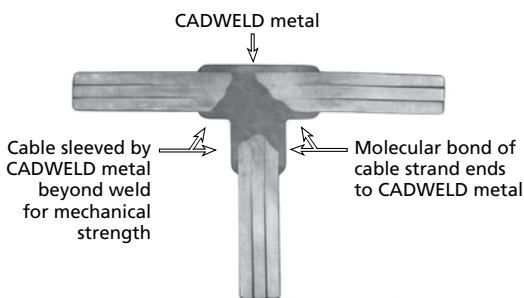

A CADWELD welded connection produces a joint (or connection) superior in performance to any known mechanical or pressure type surface-to-surface contact connector. By virtue of its molecular bond, a CADWELD welded connection will not loosen or increase in resistance over the lifetime of the installation.

### **CADWELD Welded Connections Offer the Following Advantages:**

- Current carrying (fusing) capacity equal to that of the conductor.
- Will not deteriorate with age.
- Permanent molecular bond that cannot loosen or corrode.
- Will withstand repeated faults.
- Low labor costs.
- Made with inexpensive, lightweight equipment — saves time on the job site.
- No special skills are required.
- No external power or heat required.
- Can be checked for quality by visual inspection.
- Portable system.

# It's Easy to Make CADWELD® Connections

Detailed instructions and safety precautions are provided with every CADWELD® mold. **You must read and understand all instructions before making a connection.**

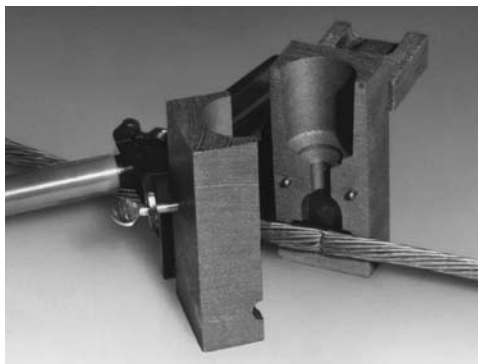

1.
  - Dry the mold and the conductors.
  - Clean the conductors.
  - Place cable ends in the mold.

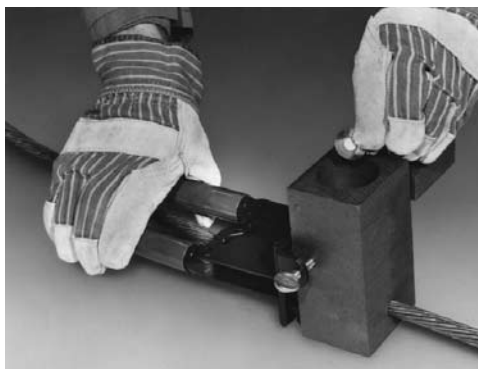

2.
  - Close the handles to lock the mold.
  - Drop the metal disk into the mold.



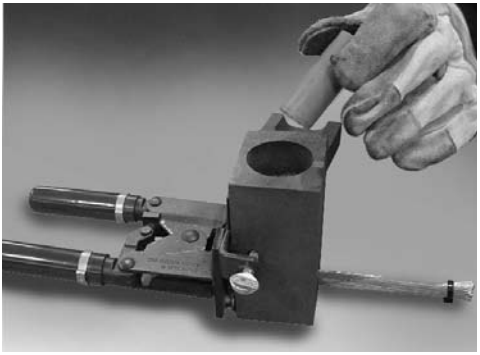

**3.**

- Dump the welding material into the mold.
- Sprinkle the starting material over the welding material and onto the lip of the mold.

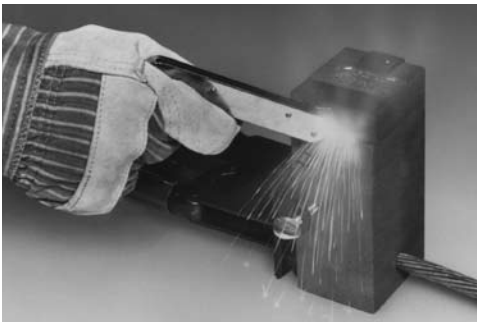

**4.**

- Close the cover and ignite.
- Open the mold after the metal solidifies.
- Remove slag from mold before next connection.

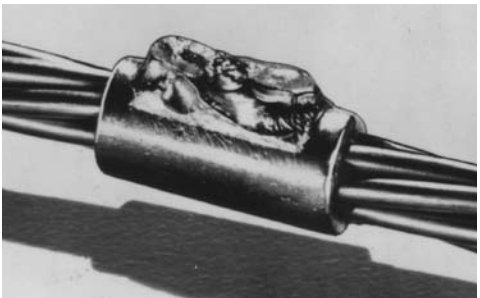

**5.**

- A completed CADWELD® connection.

## **CADWELD® Quality Standards**

All CADWELD® materials are produced to high standards under stringent quality control. All CADWELD connections are designed and tested using CADWELD molds, welding materials, and accessories.

In the absence of any standards, national or international, we cannot accurately predict the individual product standards of our competition, either known or unknown. Therefore, mixing of one manufacturer's molds with another manufacturer's welding materials can predictably lead to finished welds that do not meet the standards of either manufacturer. After all, one of the advantages of exothermic welding as a welding process is the fact that it is pre-engineered.

## **Specifications for CADWELD® Connections**

All grounding system connections shall be made by the CADWELD process. Connections shall include, but not be limited to, all cable to cable splices, T's, X's, etc.; all cable to ground rods, ground rod splices, cable to steel and cast iron; and cable lug terminations.

Procedures listed in all CADWELD instructions shall be followed. Molds shall not be altered in the field.

All materials used (molds, welding material, tools, accessories, etc.) shall be CADWELD materials, manufactured by ERICO. Materials of different manufacturers shall not be mixed.





# CADWELD® Mold Inspection

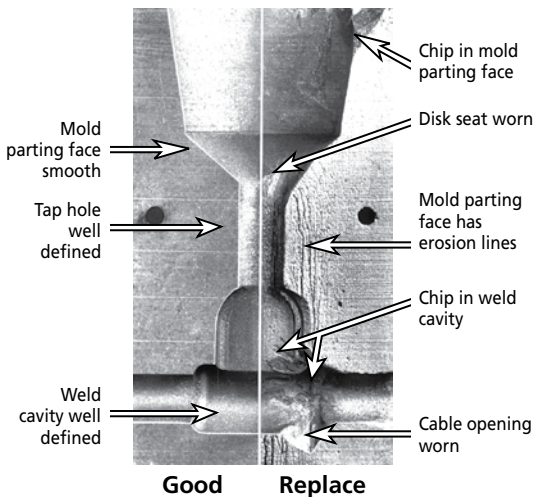

A CADWELD® mold is designed to last for an average of 50 connections. This will vary according to the care given the mold during use.

**Inspect the mold regularly. Check the following items to determine if a mold should be replaced:**

## **Cable Opening**

- The conductor should fit snugly. A loose fit will cause leakage.
- The opening should not be chipped or worn

## **Weld Cavity**

- The cavity should be well defined.
- There should be no chips or gouges.

## **Tap Hole**

- The tap hole should be well defined.

## **Disk Seat**

- The seat should not be worn or chipped; the disk must seat properly.

## **Mold Parting Face**

- The parting face should not be chipped.
- The parting face should always be cleaned properly. Use a clean shop towel or newspaper and wipe clean. Using a wire brush to clean the mold will cause erosion and quickly destroy the mold.

# Inspection of CADWELD® Connections

## General Indicators

Proper inspection of a CADWELD® connection relies on the judgment of the field personnel. Look closely at the size, color, surface finish, and porosity of the connection.

Following the guidelines below will assist in making meaningful inspections. Photographs of good, acceptable, and reject connections appear on pages 14 – 17.

### Size

1. No portion of the conductor within the confines of the weld should be exposed.
2. Maximum depression under the riser on horizontal connections (after the slag has been removed) should be no lower than the top of the conductor.

A low fill indicates:

- (a) Not enough welding material was used.
  - (b) Excessive leakage of molten metal.
  - (c) Improper positioning of the conductor inside the mold.
  - (d) Movement of conductor.
3. Excessively high fill (tall riser) indicates:
    - (a) Too large welding material size was used (connection is still acceptable).
    - (b) Apparent volume increase due to contaminants in conductor or mold (see "Porosity" on page 12).

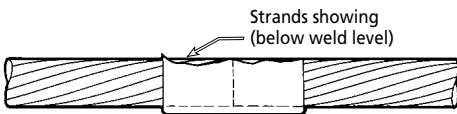

**Unacceptable**



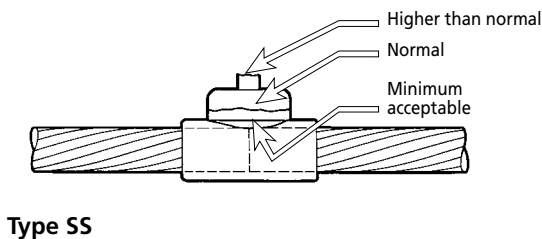
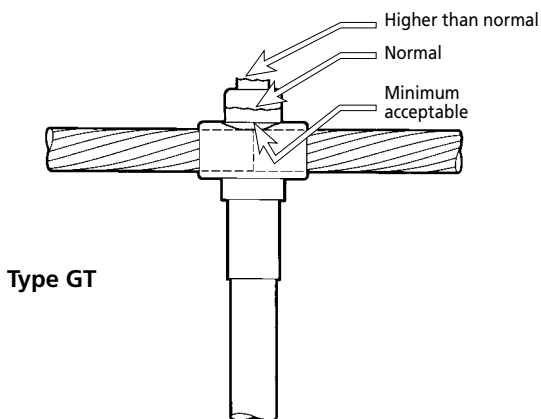
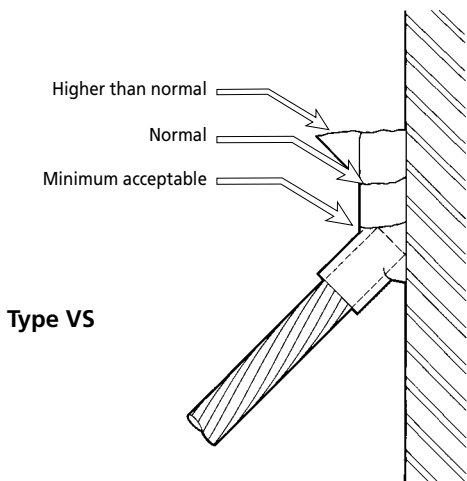

# Inspection of CADWELD® Connections

## *General Indicators (continued)*

### **Color**

The color of a CADWELD® connection is best seen after a light wire brushing of the connection. It should normally be gold to bronze in color. Occasionally, it may be silvery at the top. This silver color indicates “tin sweat” of the surface, a normal condition. A CADWELD connection to cast iron or galvanized surfaces is often silvery due to alloying with the metals.

### **Surface Finish**

The surface of a CADWELD connection should be reasonably smooth and free of major slag deposits. If slag deposits cover more than 20% of the connection surface, or if any cable strands are exposed after slag has been removed, the connection must be rejected.

### **Porosity**

The connection should be essentially free from porosity. Excessive porosity is normally the result of contaminants (water, oil, dirt, etc.) in the conductor and/or mold. A few small pinholes may be present on the surface of the riser. The depth of a pinhole must never extend beyond the center of the conductor. To check the depth, probe the pinhole with a 1/32-in.-diameter wire (paper clip). Reject the connection if the depth of the pinhole extends beyond the center of the conductor.



# Inspection of CADWELD® Connections

## *Visual Inspection*

### Photographic Guides

Like all electrical connections, a visual inspection is no guarantee of performance. Crimped or bolted connections cannot be inspected visually, but CADWELD® connections can be visually inspected and provide an indication of the quality of the weld. Visual inspection is recommended as a practical minimum.

Use the photographs on the following pages as a guide to visual inspection. CADWELD connections are normally rated as good, acceptable or reject.

A **good** connection is a normal weld with only minor surface imperfections.

An **acceptable** connection is a less than normal weld, but a good performing weld. Imperfections indicate that 1) a new mold is required, 2) a change in procedure is necessary, or 3) the proper mold conductor and/or welding material should be used.

A **reject** connection shows inadequate fill or an extra high riser due to 1) use of incorrect procedure, 2) use of incorrect equipment and/or equipment worn beyond its useful life, or 3) use of incorrect material.

# Inspection of CADWELD® Connections

## *Photographic Guides*

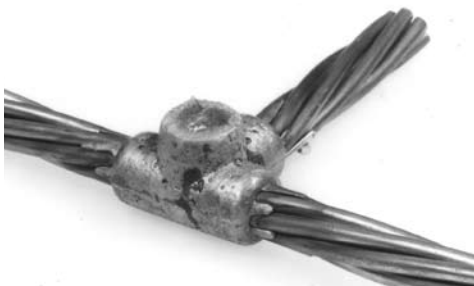

### **Good.**

A solid weld with only minor surface imperfections.

---

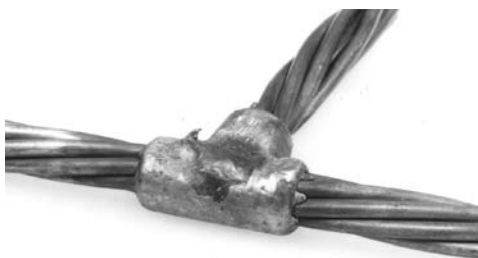

### **Acceptable.**

Fill is lower than normal, but still sufficient.

---



### **Acceptable.**

A worn or incorrect mold was used, allowing leakage around conductor. The fill in this connection is sufficient to allow it as acceptable. Attention to mold is required prior to making next connection.





**Acceptable.**

The presence of water/moisture in conductor strands or mold indicates that one or both were not properly dried. Although the riser is porous, the weld is solid. The degree of porosity is not sufficient to reject this connection.

---

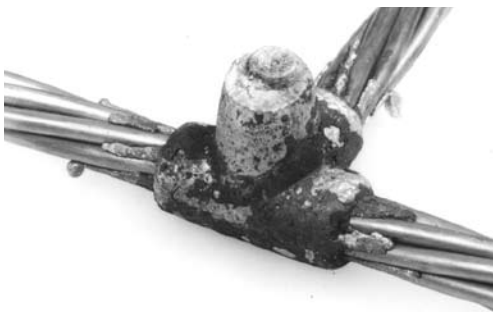

**Reject.**

Extreme amounts of slag on surface are caused by welding material leaking past disk or complete lack of disk. Inspect the condition of mold disk seat and check disk positioning prior to making the next connection.

---

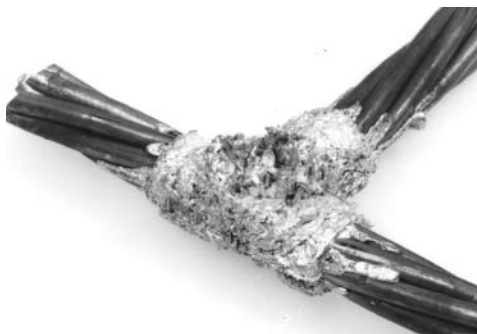

**Reject.**

Excessive water in cable strands and/or mold. Cable and mold must be dried by heating.

# Inspection of CADWELD® Connections

*Photographic Guides (continued)*



**Reject.**

Light carbon traces on cable and connection are evidence of oil on cable strands. Oily cables must be cleaned with safety solvent.

---



**Reject.**

Heavy carbon coating on cable and connection is evidence of large amounts of oil or grease on cable. Cable must be cleaned with safety solvent.





**Reject.**

Fill too low. Weld cavity was not filled over cable strands. "Fins" indicate that the mold was not closed tightly due to incorrect mold, incorrectly adjusted handle clamp, or presence of foreign material in mold parting line. Before making the next connection, check the mold for each of the above.

---



**Reject.**

Fill too low. Weld cavity was not filled over cable strands. Absence of leakage indicates that welding material size was incorrect (too small) or thru conductor moved.

# Field Situation Guide

Most field difficulties can be overcome by checking the following problems.

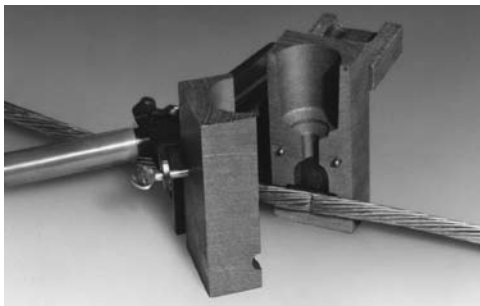

## PROBLEM A

**The mold doesn't close tightly.**

*Check for:*

1. Adjustment of handle clamps.
2. Cables out of round or bent.
3. Dirt or slag in mold parting line.
4. Correct cable size.

*NOTE: Use "C" clamp if necessary.*

---

## PROBLEM B

**The connection is covered with excessive slag.**

*Check for:*

1. Welding material leaking past the disk, caused by:
  - (a) Chipped graphite at tap hole.
  - (b) Disk moved when welding material was dumped.
  - (c) Disk not properly seated.
  - (d) Disk was not installed.

*NOTE: A small amount of slag on the surface is not abnormal.*

---

## PROBLEM C

**Molten metal "spits" out of the crucible when making a connection.**

*Remedy:*

1. See Problem D.



---

*PROBLEM D*

**The connection is porous**

*Check for:*

1. Presence of moisture either in conductor or mold.

*Remedy:*

- (a) Dry the conductor by wiping and heating.
- (b) Heat mold with torch (to above 212°F) or by igniting welding material in mold without any conductors, taking care to prevent burns from the hot material running out of the mold.

*NOTE: Do not use the second method of heating if the mold has wear plates.*

*Check for:*

2. Other contaminants (oil, insulation, etc.) present in conductors.

*Remedy:*

- (a) Use a safety solvent to wash the conductor, then dry it.
- (b) If insulation is present between strands, remove it.

*Check for:*

3. Mold packing material in weld cavity of mold.

*Remedy:*

- (a) Always apply mold packing material to conductor after mold is closed.

---

*PROBLEM E*

**The conductors do not weld**

*Check for:*

1. Conductors were not properly cleaned and dried.

*Remedy:*

- (a) Remove oxides with a wire brush. If heavily oxidized, have fresh-cut conductor end and use CADWELD® Heavy Duty molds.
- (b) Dry conductors with a torch.

*Check for:*

2. Conductors not properly positioned in the mold.

*Remedy:*

- (a) Check for proper gap or butting as required (see the mold tag and read the instructions packaged with mold).

## Field Situation Guide *(continued)*

(b) Check to be sure gap is centered under tap hole.

*NOTE: In some cases, the run (thru) conductor must be cut and gapped. Follow instructions for same or use CADWELD® Heavy Duty molds.*

---

### PROBLEM F

**The welding material leaks around the conductor.**

*Remedy:*

1. Use packing material around the conductor after the mold is closed.
  2. Use molds with wear plates (which also act as chill plates).
  3. Check for the proper mold. Mold must be sized for the cable being welded.
  4. If the mold is excessively worn, replace with a new mold.
- 

### PROBLEM G

**The connection has “fins”— metal is lost.**

*Check for:*

1. Mold not completely closed.
  2. Mold worn beyond useful life and needs replacement.
- 

### PROBLEM H

**The cables pull out of the mold during welding.**

*Remedy:*

1. Use a clamp (CADWELD® B-265) or other means to prevent movement of conductors when welding.
- 

### PROBLEM I

**Insufficient fill material to cover conductors**

*Check for:*

1. Use of proper welding material size (see mold tag).
  2. Too large a gap between conductors (see positioning instructions).
  3. Mold leakage.
- 



**Remedy:**

- (a) See Problem F.
- (b) See Problem G.
- (c) See Problem H.

4. Conductor movement.

---

**PROBLEM J**

**The riser is too high.**

**Check for:**

- 1. Use of proper welding material size (see mold tag).
- 2. Moisture in mold or conductor.

**Remedy:**

- (a) See Problem D.
- 

**PROBLEM K**

**The mold wears out quickly.**

*(Molds should produce an average of 50 connections.)*

**Remedy:**

- 1. Use CADWELD® B-265 cable clamp for hard-drawn copper or DSA Copperweld®.
  - 2. Clean the mold with a soft brush, clean cloth, or newspaper. DO NOT USE A WIRE BRUSH.
  - 3. Use care in removing the mold from a finished connection to prevent chipping of mold.
- 

**PROBLEM L**

**When welding to steel, the weld does not "stick" to the steel.**

**Remedy:**

- 1. Clean the steel with a rasp or grinder to bright metal. When grinding, use an ERICO approved grinding wheel only. All mill scale, paint, and/or other coating must be removed. Wire brushing will NOT suffice. Grease must be removed with safety solvent before cleaning.
  - 2. Clean galvanized surfaces with a wire brush or emery cloth. However, extra heavy galvanized steel must be cleaned with a rasp.
  - 3. If the steel is moist, heat with a torch (from the back side if possible). Any carbon deposit from the flame must be removed.
  - 4. If conductors are not in proper position, check the instruction sheet.
-

## Field Situation Guide *(continued)*

### PROBLEM M

**When welding to ductile iron or cast iron, the weld does not “stick” to the surface.**

#### *Remedy:*

1. Remove all coatings before cleaning.
2. Clean the surface with a rasp or grinder to bright metal. When grinding, use an ERICO-approved wheel only.
3. Clean the surface with a safety solvent after grinding or rasping.
4. Use CADWELD® XF-19 alloy welding material (orange cap).

## CADWELD® ONE SHOT Connections

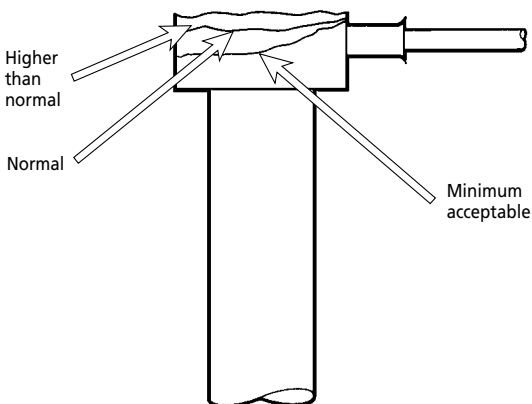

CADWELD® ONE SHOT connections do not always follow the same rules as connections made with graphite molds.

1. No portion of the cable within the confines of the sleeve should be exposed.
2. Maximum depression under the riser (after the slag has been removed) should be no lower than the bottom of the cable. Lower fill indicates excessive leakage of molten metal or improper positioning of the CADWELD ONE SHOT mold.



# Field Situation Guide for CADWELD® ONE SHOT Applications

Below are typical field situations related to CADWELD® ONE SHOT connections.

---

## *PROBLEM A*

**Weld does not “stick” to ground rod.**

### *Remedy:*

1. Ground rod must be cleaned with a rasp to bright metal. All scale and/or other coating must be removed. Wire brushing will not suffice. Grease must be removed with a safety solvent before cleaning.
  2. If conductors are moist, heat with a torch. Any carbon deposit from the flame must be removed.
- 

## *PROBLEM B*

**Porous connections.**

### *Remedy:*

1. Dry the conductors by heating with a torch.
- 

## *PROBLEM C*

**Discolored, blackened connections.**

### *Remedy:*

1. Remove insulation and clean oil from conductor with a safety solvent. Then, dry surfaces before welding.
- 

## *PROBLEM D*

**Welding material leaks.**

### *Remedy:*

1. CADWELD ONE SHOT mold is wrong size. See catalog.
- 

## *PROBLEM E*

**Insufficient fill metal.**

### *Remedy:*

1. Conductor not properly positioned in CADWELD ONE SHOT mold.

#### WARNING

ERICO products shall be installed and used only as indicated in ERICO's product instruction sheets and training materials. Instruction sheets are available at [www.erico.com](http://www.erico.com) and from your ERICO customer service representative. Improper installation, misuse, misapplication or other failure to completely follow ERICO's instructions and warnings may cause product malfunction, property damage, serious bodily injury and death.

#### WARRANTY

ERICO products are warranted to be free from defects in material and workmanship at the time of shipment. NO OTHER WARRANTY, WHETHER EXPRESS OR IMPLIED (INCLUDING ANY WARRANTY OF MERCHANTABILITY OR FITNESS FOR A PARTICULAR PURPOSE), SHALL EXIST IN CONNECTION WITH THE SALE OR USE OF ANY ERICO PRODUCTS. Claims for errors, shortages, defects or nonconformities ascertainable upon inspection must be made in writing within 5 days after Buyer's receipt of products. All other claims must be made in writing to ERICO within 6 months from the date of shipment or transport. Products claimed to be nonconforming or defective must, upon ERICO's prior written approval in accordance with its standard terms and procedures governing returns, promptly be returned to ERICO for inspection. Claims not made as provided above and within the applicable time period will be barred. ERICO shall in no event be responsible if the products have not been stored or used in accordance with its specifications and recommended procedures. ERICO will, at its option, either repair or replace nonconforming or defective products for which it is responsible or return the purchase price to the Buyer. THE FOREGOING STATES BUYER'S EXCLUSIVE REMEDY FOR ANY BREACH OF ERICO WARRANTY AND FOR ANY CLAIM, WHETHER SOUNDING IN CONTRACT, TORT OR NEGLIGENCE, FOR LOSS OR INJURY CAUSED BY THE SALE OR USE OF ANY PRODUCT.

#### LIMITATION OF LIABILITY

ERICO excludes all liability except such liability that is directly attributable to the willful or gross negligence of ERICO's employees. Should ERICO be held liable its liability shall in no event exceed the total purchase price under the contract. ERICO SHALL IN NO EVENT BE RESPONSIBLE FOR ANY LOSS OF BUSINESS OR PROFITS, DOWNTIME OR DELAY, LABOR, REPAIR OR MATERIAL COSTS OR ANY SIMILAR OR DISSIMILAR CONSEQUENTIAL LOSS OR DAMAGE INCURRED BY BUYER.

Copperweld is a registered trademark of Copperweld Steel Company, Fayetteville, TN.  
Cor-Ten is a registered trademark of United States Steel Corp.  
Everdur is a registered trademark of Anaconda Copper Co.

Copyright ©2001, 2003, 2005, 2006, 2008, 2010 ERICO International Corporation.  
All rights reserved.

CADDY, CADWELD, CRITEC, ERICO, ERITECH, ERIFLEX, and LENTON are registered trademarks of ERICO International Corporation.

PH: 800-248-9353  
FAX: 800-677-8131  
[www.erico.com](http://www.erico.com)

**ERICO**<sup>®</sup>  
A7D E1307LT10NAEN 7.5M1010