

REVISIONS				
ZONE	REV	DESCRIPTION	DATE	APPROVED
	A	A-APR-08 SMKL-1	APRIL'08	

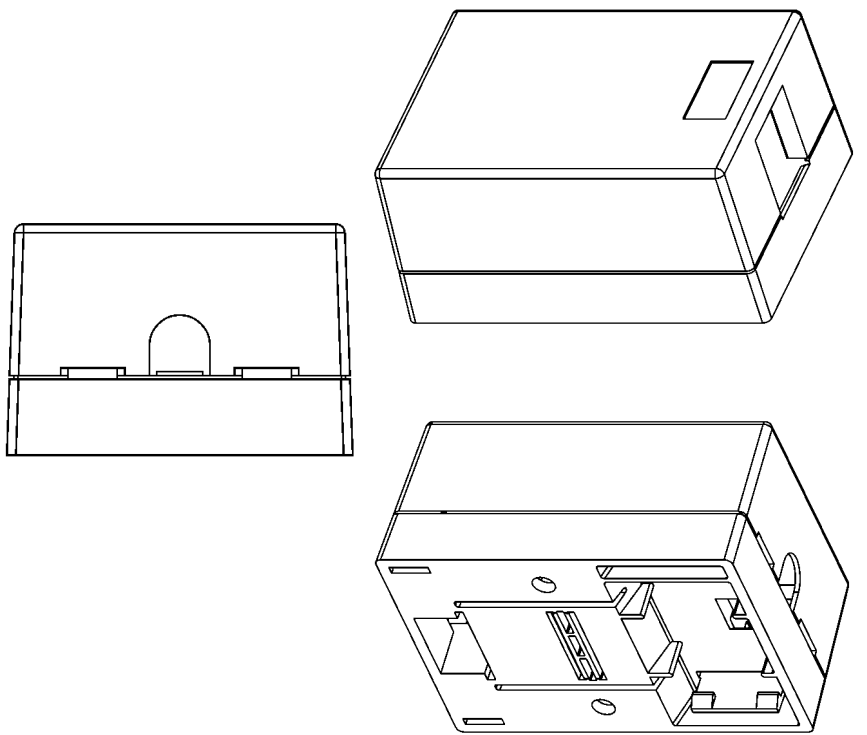

NOTES:
1. MATERIAL: ABS UL 94V-0

UNLESS OTHERWISE SPECIFIED DIMENSIONS ARE IN MILLIMETERS (INCHES) TOLERANCES:		MATERIAL: AS NOTES			
MM	IN	ANGULAR			
.X ± .2	.X ± .016	X ± 1°			
.XX ± .1	.XX ± .008	.X ± .5°			
	.XXX ± .004				
PROJECT ID	SPCS - PD	FILE	SPCS - PD.KSM-MMB.SMKL1	DATE	APRIL'08
16295 NW 13th Ave, Ste A, Miami, FL 33169, PH: (305) 944-7710, FX: (305) 949-4483, www.signamax.com					
PROCESS	INITIALS	NAME	DATE	TITLE	
DRAWN				SMKL-1 (1-PORT SURFACE MOUNT BOX)	
CHECK				SIZE	CAGE CODE
APPROVED				A	DWG. NO.
					REV
					A
SCALE	1:1	UNIT	MM (IN)	SHEET	1 OF 1