

SP-5600TP Premium Display

SP5000 SERIES



Features:

- XGA Display TFT Touch Panel
- 16 million colors
- Compatible with power or open box modules
- USB access via front bezel
- Auto-scaling functionality
- Embedded mounting clips for easy installation

Performance Specifications

Model	SP-5600TP	
Part Number	PFXSP5600TPD	PFXSP5600TPDF0C
Graphics Display Resolution	1,024 x 768 pixels XGA	
Display Type and Size	TFT Color LCD 12.1"	
Display Colors	16 Million Colors	
Effective Display Area	W245.76 x H184.32 mm (W9.68 x H7.26 in.)	
Touch Screen	Resistive film (analog, multi-touch)	
Backlight	White LED	
Backlight Service Life	50,000 hours or more (continuous operation at 25 °C [77 °F] before backlight brightness decreases to 50%)	
Brightness	Max.:400cd(Typ) Min.:4cd(Typ) 0...100 (Adjusted with touch panel or software) ^{*1}	
Front USB	Type A (V2.0) x1, Mini B (V2.0) x1	

^{*1} The maximum and minimum brightness Value is the reference Value, because there are individual differences by the liquid crystal.

General Specifications

Models	SP-5600TP	
Part Number	PFXSP5600TPD	PFXSP5600TPDF0C
Conformal Coating	-	Yes
Input Voltage	12-24 Vdc (limits 10.8 -29.9 Vdc)	
Voltage Drop	12 Vdc: 1.25 ms or less/ 24 Vdc: 5 ms or less	
In-Rush Current	30 A or less	
Voltage Endurance	1,000 Vac, 20 mA for 1 minute (between charging and FG terminals)	
Insulation Resistance	500 Vdc, 10 MQ or more (between charging and FG terminals)	
Power Consumption	56W or less(display module with box module) ^{*1} 21W or less (display module only)	
Surrounding Air Temperature	0...60 °C [32...140 °F]	
Storage Temperature	-20...60 °C [-4...140 °F]	
Certifications	CE, ATEX, RoHS, GOST-R, UL 508/c-UL, CSA C22.2 N°142, KC, EAC, ABS, BV, CCS, DNV, GL, LR, RINA, NK	
Ratings	IP65 (IP65F, IP66F or IP67F, when use enhanced front USB cover), EN61000-6-4, EN61000-6-2, CSA C22.2No213, ANSI/ISA 12.12.01, Class 1 Div 2 Groups A, B, C, and D when installed per Control Drawing No. HRB78717	
Surrounding Air and Storage Humidity	10%...90% RH (Non condensing, wet bulb temperature 39 °C [102.2 °F] or less)	
Dust	0.1 mg/m ³ (10-7 oz/ft ³) or less (non-conductive levels)	
Pollution Degree	For use in Pollution Degree 2 environment	
Corrosive Gas	Free of corrosive gases	
Atmospheric Pressure (Operating Altitude)	800...1,114 hPa (2,000 m [6,561 ft] or lower)	
Vibration and Shock Resistance	IEC/EN 61131-2 compliant	
Electrostatic Discharge Immunity	Contact Discharge Method: 6 kV (IEC/EN 61000-4-2 Level 3)	
Weight	3.2kg (7.1 lb) or less	
External Dimensions	W315 x H241 x D67 mm(W12.4 x H9.49 x D2.64 in.)	
Panel Cut Dimensions	W301.5 x H227.5 mm(W11.87 x H8.96 in.) ² Panel thickness area: 1.6...5 mm (0.06...0.2 in.) ³	
Warranty	Two (2) years	

^{*1} The power consumption for the combined unit of Box Module and Display Module equals the sum of the power consumption for the Modules. ^{*2} Even if the installation wall thickness is within the recommended range for the "Panel Cut Dimensions", depending on wall's material, size, and installation location of this product and other devices, the installation wall could warp. To prevent warping, the installation surface may need to be strengthened.^{*3} The weight for the combined unit of Box Module and Display Module equals the sum of the weight for the Modules.

External Dimensions

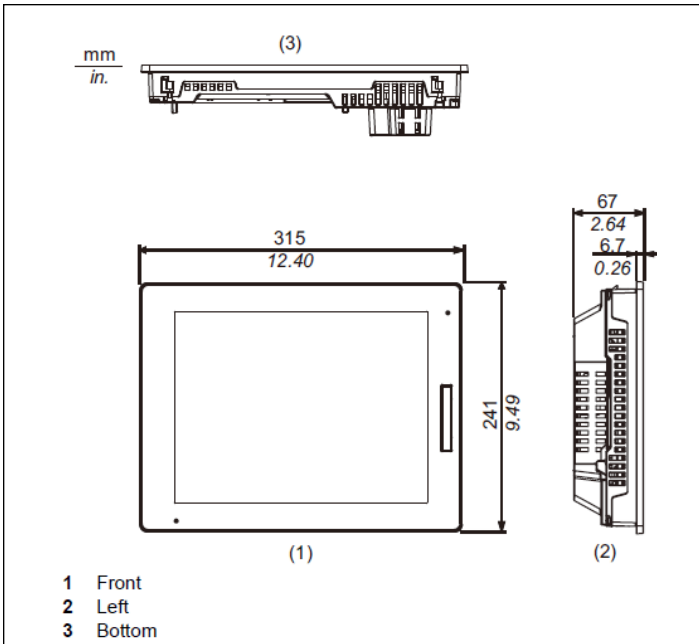

Panel Cut Dimensions

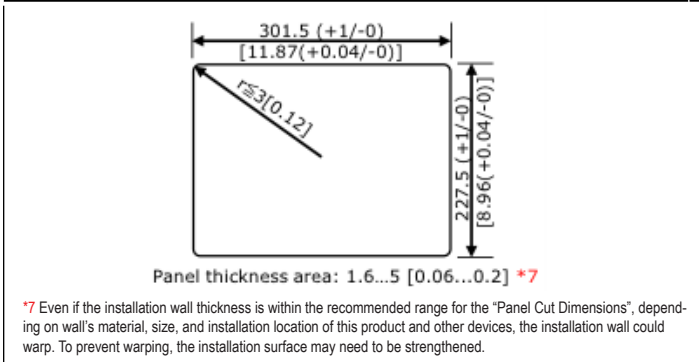

Multiple Screen Size Options

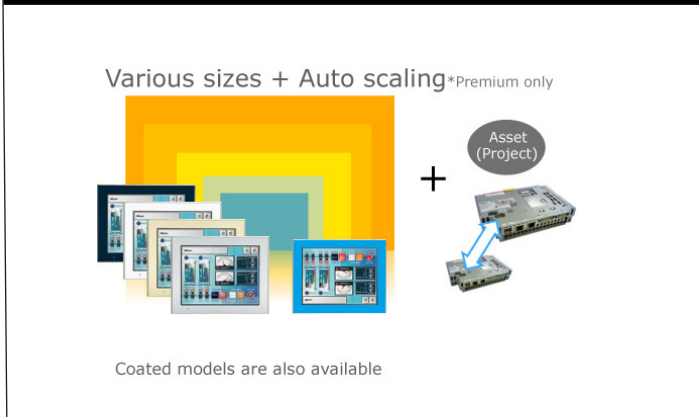

Ordering Information

Type	Model Numbers	Description
SP-5600TP	PFXSP5600TPD	12.1-inch TFT, 16M colors, XGA 1024 x 768 pixels, Analog Touch Panel(Multi touch), Front USB A/mini-B I/F x 1 each, DC24V
SP-5600TP Conformal Coating		12.1-inch TFT, 16M colors, XGA 1024 x 768 pixels, Analog Touch Panel(Multi touch), Front USB A/mini-B I/F x 1 each, DC24V with conformal coating

Options

Part Number	Product Name	Description
PFXZCDCVUS1	Enhanced Front USB Cover (With Screw)	Front USB cover with fixing screw, corresponding to IP66F, IP67F, Type 1/4X Indoor use only /13 or ATEX certification (5 pieces/set)
PFXZCDWG121	12.1-inch Installation Gasket	Provides dust and moisture resistance when SP is installed into a solid panel (1 piece)*
PFXZCDDS122	12.1-inch Screen Protection Sheet	Disposable, dirt-resistant sheet for the SP unit's screen (5 sheets/set)

Modular Design and Easy Maintenance

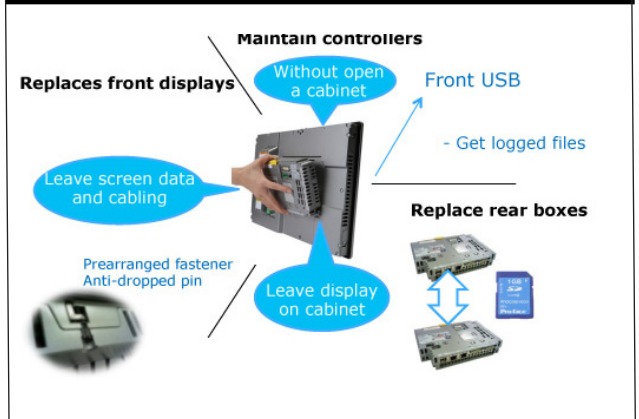

Pro-face America
Phone: 734.477.0600
Fax: 734.864.7347
www.profaceamerica.com

Customer Service Hotline: 800.289.9266

For more information
ACCESS www.profaceamerica.com

Pro-face