



Project: _____

Fixture Type: _____

Location: _____

Contact/Phone: _____

TRAC-MASTER®

Quick Jack Mountings

QUICK JACK POWER CLAMP

TQJDL-CLAMP

PRODUCT SPECIFICATIONS

Construction 20 gauge die formed steel housing • Polyester powder coat paint finish • Available in white or black finishes • Clamp mechanism enables clamping of up to 2-3/4" thick flat surfaces or 1-3/4" dia. pipe • May be operated in any orientation • Includes Quick Jack receptacle which can be easily rotated from top of housing to end of housing • Provided with matching color 8' grounded cord & plug for maximum portability and adjustability.

Electrical Hatch RS-12-60M-LED 60VA 12VAC solid state electronic transformer • 120VAC input • Compatible with most 12VAC LED lamps (by others) – contact lamp manufacturer to confirm compatibility • Also compatible with 50W max. 12VAC halogen lamps • May be used with any Juno Quick Jack fixture • Includes pushbutton on/off switch.

Labels ETL classified to UL 153 for use in U.S. • ETL classified to CSA C22.2 No. 12 for use in Canada.

Product specifications subject to change without notice.



PRODUCT CODES

Catalog Number	Finish	Description
TQJDL-CLAMP-BL	Black	12V, 50W Quick Jack Power Clamp
TQJDL-CLAMP-WH	White	12V, 50W Quick Jack Power Clamp

DIMENSIONS

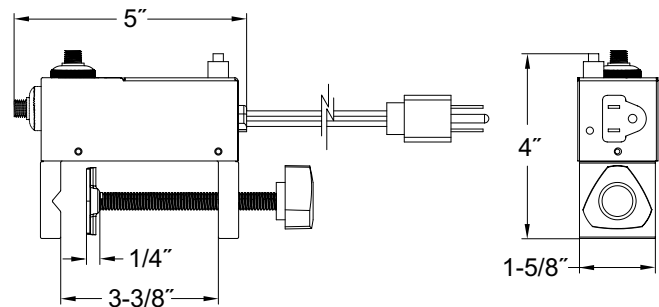

ENGINEERING DATA

TQJDL-CLAMP	
Input Voltage	120VAC
Input Current @ 50W	0.37A
Nominal Output	12VAC
Max. Load	50 Watts (VA)
Operating Frequency	>20kHz
Power Factor	>.98%
T.H.D.	<20%