



8" SQUARE TC HOUSING

INCANDESCENT LAMPS TC6

Project: _____

Fixture Type: _____

Location: _____

Contact/Phone: _____

PRODUCT DESCRIPTION

TC Housing designed for use in non-insulated areas • If installed where insulation is present, the insulation must be pulled back 3" from all sides of the TC housing.

PRODUCT SPECIFICATIONS

Lamp One 100W A19 lamp.

Socket Medium base porcelain with nickel-plated copper screw shell.

Trims Trim selection shown below.

Labels UL listed for through-branch wiring, damp locations and IP

- Product thermally protected against improper use of insulation
- Union made • UL Listed/CSA certified.

Testing All reports are based on published industry procedures; field performance may differ from laboratory performance.

Specifications subject to change without notice.

INSTALLATION

Real Nail® 3 Bar Hangers Telescoping, Patented (US Patent D552,969) Real Nail 3 system permits quick placement of housing anywhere within 24" O.C. joists or suspended ceilings • Integral T-bar notch and clip secures housing in suspended ceiling grid – no accessory clips required • 24" expansion stop allows quick placement of fixture in standard grid spacing • Bars scored in two locations for fast, clean breaking, allowing housing installation in tight applications • Bars captive to mounting frame • Edge-mounted for extra strength • Captive bugle-headed ring shank nail for quick one-step installation and easy removal with claw hammer for fixture relocation • Quick-Loc slot and oversized locking set screw lock fixture in position • Bar hanger foot contoured to align to bottom of construction joist • Alternate mounting holes included.

Junction Box Pre-wired junction box provided with (5) 1/2" and (1) 3/4" knockouts, (4) Romex connectors and ground wire, UL listed/CSA certified for through-branch wiring, maximum 8 No. 12 AWG 90° C branch circuit conductors (4 in, 4 out) • Junction box provided with removable access plates • Knockouts equipped with pryout slots.

Mounting Frame 22-gauge die-formed galvanized steel mounting frame • 13 1/2" L x 9 5/8" W, (excluding bar hangers) • Rough-in section (junction box, mounting frame, housing and bar hangers) fully assembled for ease of installation.

Housing TC housing, 22-gauge white painted steel • Housing is vertically adjustable to accommodate up to a 1" ceiling thickness.

DIMENSIONS

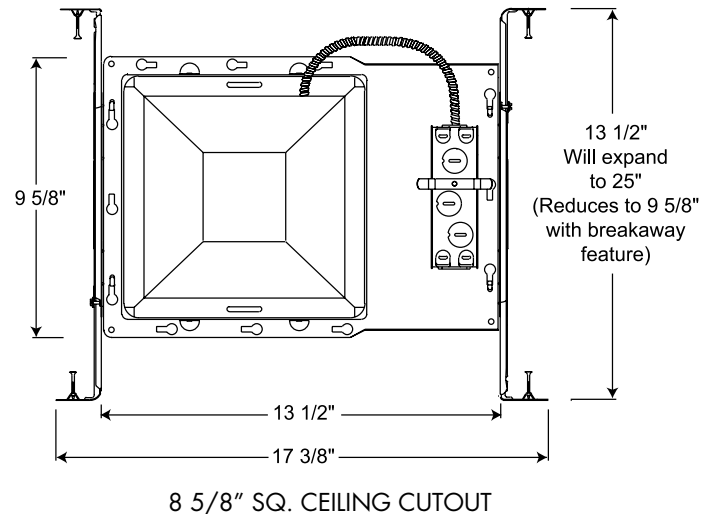
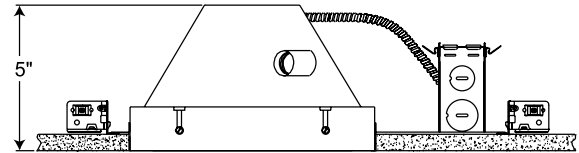

PRODUCT CODES

Catalog Number	Input Voltage	Lamp Rating
TC6 8" Incandescent Square Non-IC New Construction Housing	120V	100W A19

TRIMS/LAMPS

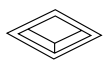

Catalog Number	Description	Max. Lamp Rating
60 WH	8" Crystal Diffuser Trim, White	100W A19

Trim Size: 9 5/8" SQ.

Housing and trim can be ordered together or separate, but will always ship separately.